

100W Series single output switching power supply

SMV-100 Series



Dimension: 185 × 69 × 43mm

Features:

- Constant voltage style power supply
- Universal AC input / Full range
- Small volume, low weight, high efficiency
- Protections : short circuit/over load/over voltage/over temp
- Cooling by free air convection
- Fully encapsulated with IP67 level
- 100% full load burn-in test
- 1 Year warranty

SPECIFICATION

Model		SMV-100-12	SMV-100-24	SMV-100-36
Output	DC voltage	12V	24V	36V
	Voltage tolerance	± 1%	± 1%	± 1%
	Rated current	8.5A	4.2A	2.8A
	Current range	0 ~ 8.5A	0 ~ 4.2A	0 ~ 2.8A
	Rated power	102W	101W	101W
	Ripple&noise	100mVp-p	150mVp-p	150mVp-p
	Setup, rise, hold up time	800ms,30ms,24ms/230VAC		
Input	Voltage range	90 ~ 264VAC 47 ~ 63Hz, 126 ~ 373VDC		
	AC current	2.4A/115V 1.2A/230VAC		
	Efficiency	82%	84%	85%
	Inrush current	Cold start40A/230VAC		
	leakage current	< 2.5mA/240VAC		
Protection	Overload	Rated output power105% ~ 135%Start overload protection		
		Protection type: hiccup mode, auto-recovery after fault condition is removed		
	Over voltage	15.6 ~ 17.8V	30.6 ~ 33.2V	42.6 ~ 44.2V
		Protection type: hiccup mode, auto-recovery after fault condition is removed		
	Over temperature	Shell temp≥85°C, Start over temp protection		
Protection mode: cutoff output, auto-recovery after temperature become normal				
Environment	Working temp, humidity	-10°C ~ +60°C;20% ~ 90%RH(Please refer to "derating curve")		
	Storage temp, humidity	-20°C ~ +85°C;10% ~ 95%RH Non-condensing		
	Withstand vibration	10 ~ 500Hz, 2G 10min./1Cycle, Period for 60min, Each axes		
Safety	Withstand voltage	I/P-O/P: 1.5KVAC I/P-FG: 1.5KVAC O/P-FG: 0.5KVAC		
	Isolation resistance	I/P-O/P: I/P-FG,O/P-FG: 100M Ohms/500VDC		
Fit standard	Safety standard	Fit UL1012 IP67		
	EMC Standard	Fit EN55022, CLASSA		
Others	Dimension	0.9kg 185*69*43 (L*W*H)		
	Weight	0.9kg/20pcs/19kg/0.91CUFT		

Note: 1. All parameters NOT specially mentioned are measured at 230VAC input, rated load and 25°C of ambient temperature.
 2. Ripple & noise are measured at 20MHz of bandwidth by using a 12" twisted pair-wire terminated with a 0.1uf & 47uf parallel capacitor.
 3. Tolerance : includes set up tolerance, line regulation and load regulation.

Mechanical specification

Unit:mm

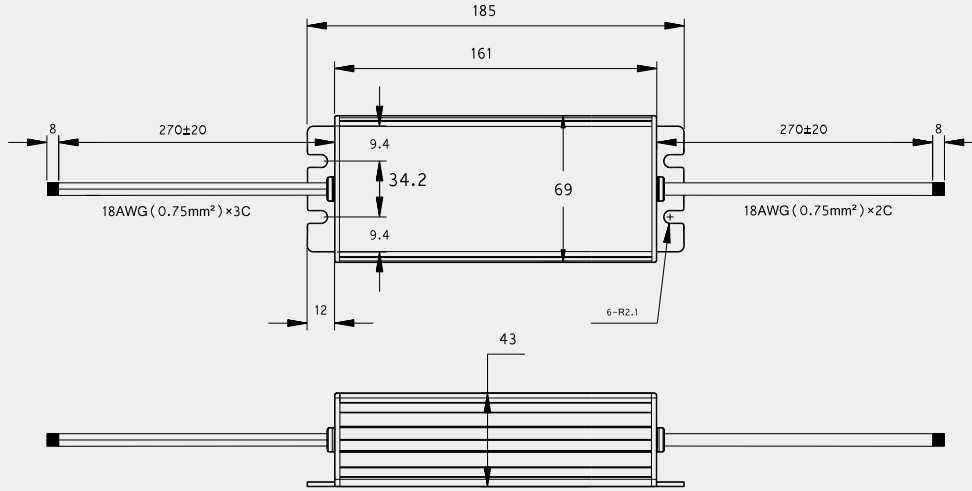

lead-out wire assignment

Input(Black three-core)		Output (White two-core)	
Brown	AC/L	Red	DC OUTPUT +V
Blue	AC/N	Black	DC OUTPUT -V
Yellow-green	FG \perp		

Block diagram

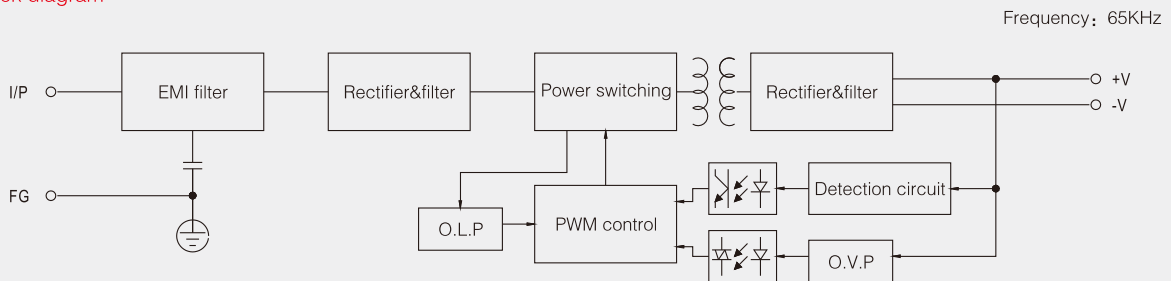

Derating curve

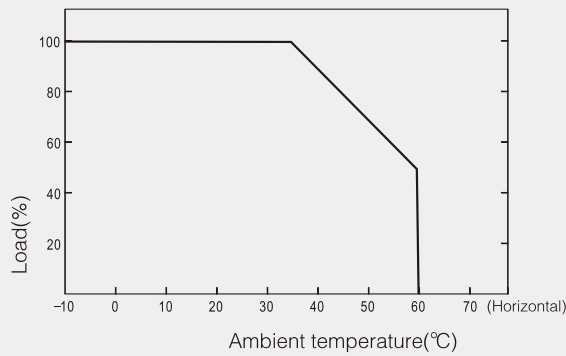

Static characteristic

