

50W Series single output switching power supply

S-50 Series



Features:

- AC input voltage range selected by switch
- Small volume, low weight, high efficiency
- Protections : short circuit/over load
- LED indicator for power on
- 100% full load burn-in test
- 1 Year warranty

Dimension: 159 × 97 × 38mm

SPECIFICATION

Model		S-50-5	S-50-12	S-50-15	S-50-24
Output	DC voltage	5V	12V	15V	24V
	Voltage tolerance	± 1%	± 1%	± 1%	± 1%
	Rated current	10A	4.2A	3.4A	2.1A
	Current range	0 ~ 10A	0 ~ 4.2A	0~3.4A	0 ~ 2.1A
	Rated power	50W	50W	50W	50W
	Ripple&noise	100mVp-p	120mVp-p	100mVp-p	120mVp-p
	DC voltage ADJ. range	± 10%	± 10%	± 10%	± 10%
	Setup, rise, hold up time	200ms,80ms,22ms/230VAC.			
Input	Voltage range	90 ~ 132VAC/180 ~ 264VAC(Selected by switch) 47 ~ 63Hz, 255 ~ 373VDC			
	AC current	1.3A/115V 0.65A/230VAC			
	Efficiency	76%	79%	79%	82%
	Inrush current	Cold start 18A/115V 36A/230VAC			
	leakage current	< 3.5mA/240VAC			
Protection	Overload	Rated output power115% ~ 150%Start overload protection			
		Protection type : part layer type current limit , auto-recovery after fault condition is removed			
Environment	Working temp, humidity	-10°C ~ +60°C;20% ~ 90%RH(Please refer to “derating curve”)			
	Storage temp, humidity	-20°C ~ +85°C;10% ~ 95%RH Non-condensing			
	Withstand vibration	10 ~ 500Hz, 2G 10min./1Cycle, Period for 60min, Each axes			
Safety	Withstand voltage	I/P-O/P: 1.5KVAC I/P-FG: 1.5KVAC O/P-FG: 0.5KVAC			
	Isolation resistance	I/P-O/P: I/P-FG,O/P-FG: 100M Ohms/500VDC			
Fit standard	Safety standard	Fit UL1012			
	EMC Standard	Fit EN55022, CLASSA			
Others	Dimension	0.5kg 159*97*38mm (L*W*H)			
	Weight	0.5kg/45pcs/23.5kg/1.45CUFT			

Note: 1. All parameters NOT specially mentioned are measured at 230VAC input, rated load and 25°C of ambient temperature.

2. Ripple & noise are measured at 20MHz of bandwidth by using a 12" twisted pair-wire terminated with a 0.1uf & 47uf parallel capacitor.

3. Tolerance : includes set up tolerance, line regulation and load regulation.

Mechanical specification

Unit:mm

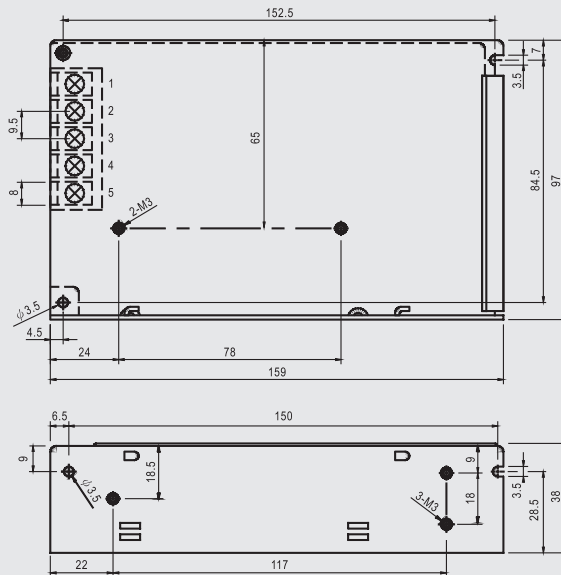

Terminal Pin No. Assignment

Pin No.	Assignment	Pin No.	Assignment
1	AC/L	4	DC OUTPUT -V
2	AC/N	5	DC OUTPUT +V
3	FG		

Block diagram

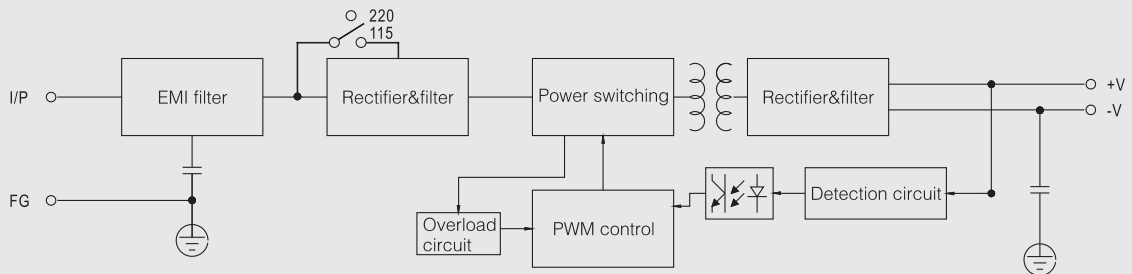

Derating curve

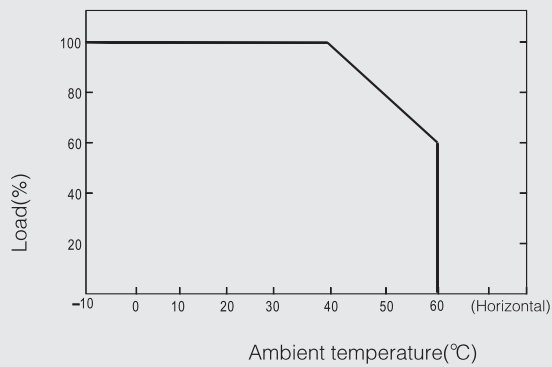

Static characteristic

